



Followspots

Arthur	
Thanks to its powerful LED engine, very narrow beam angle and long-throw capability, Arthur ensures invincible performances with a minimum output of 2000 lux at a distance of 40m (200fc at 130 ft), while offering premium light quality with a high CRI (>90) - an essential feature for a followspot whose main role is to shine a light on performers and showcase them in sublime fashion.	
RJU0186	1014
RJU0187	1014TC



Arthur LT	
Arthur LT is a Long-Throw adaptation of the original Arthur followspot with a narrower beam. Featuring a zoom range of 4° - 10°, Arthur LT provides an output that exceeds an HMI 2500W Aramis. The LT version ensures invincible performances with an output of 2000 lux at a distance of 50m (200fc at 165 ft), while offering an enhanced light quality with a high CRI (>94) - an essential feature for a followspot whose main role is to shine a light on performers and showcase them in sublime fashion.	
RJU0188	1014LT
RJU0189	1014TCLT



Cyrano 1015M	
Cyrano's narrow beam angle is suited to super-long throw distances found in the largest theatres and stadia. Its unique dimmer shutter gives Cyrano a superb dimming ability – surpassing even that of Aramis – making it indispensable for opera houses and large TV shows.	
RJU0190	1015M



Lancelot	
Lancelot's innovative optical train improves on the power and throw capabilities of its smaller counterparts to become the benchmark fixture for spectaculars. More than just a followspot, its modular accessories make it the most powerful long throw effects projector ever built.	
RJU0191	1021TM



Cricket	
The smallest of the followspot range with the optical excellence of its larger counterparts. Cricket's ultra compact dimensions and low power consumption make it the perfect introduction to Robert Juliat for discerning schools, amateur dramatics and smaller venues.	
RJU0192	1116
RJU0193	1116A



Alex	
The Alex long throw tungsten followspot blends well with conventional theatre lighting and maintains the flat beam and constant colour temperature during dimming which is so important to sensitive camera equipment. Ideal for television studios, opera houses and ballets.	
RJU0194	1117



Topaze	
The full range of features on Topaze brings Robert Juliat quality within reach of all budgets. Long lamp life and low running costs provide a powerful, cost-effective solution for mid-size theatres, shows and rental companies alike.	



Victor	
With a combination of compact dimensions, high output to rival 2500 W followspots and a hot restrike lamp and electronic PSU, Victor is perfect for rental companies. It has become the new benchmark followspot for large theatres, TV studios, fashion shows, concerts and touring.	
RJU0198	1159
RJU0199	1159B



Ginger	
The Ginger short throw tungsten followspot blends well with conventional theatre lighting and maintains the flat beam and constant colour temperature during dimming which is so important to sensitive camera equipment. Ideal for television studios, opera houses and ballets.	
RJU0205	1417



Manon	
The full range of features on Manon brings Robert Juliat quality within reach of all budgets. Long lamp life and low running costs provide a powerful, cost-effective solution for mid-size theatres, shows and rental companies alike.	



Flo	
With a combination of compact dimensions, high output to rival 2500 W followspots and a hot restrike lamp and electronic PSU, Flo is perfect for rental companies. It has become the new benchmark followspot for large theatres, TV studios, fashion shows, concerts and touring.	
RJU0207	1459
RJU0208	1459B





Sully

Sully 1156 is the perfect introduction to Robert Juliat LED followspots for discerning schools, amateur dramatics and smaller venues. Its optical excellence, ultra compact dimensions and low power consumption make it a reliable and easy to use luminaire. Sully features an exclusive 115W warm white LED source, able to deliver an output comparable to a 1000W tungsten unit, without generating heat, which also gives more comfort to the operator. Controlled both locally and remotely by DMX, this little followspot is definitely accessible to beginners as well as skilled operators.



RJU0196	1156WW
RJU0197	1156CW

Roxie2

The compact 300W spot is all about efficiency. It fits in the smallest of spaces and is the ideal energy-efficient solution for all those venues where running costs need to be significantly reduced. Roxie delivers an output comparable to most of the 575W discharge followspot available on the market. No heat, no lamp change, less maintenance. Smooth electronic dimming is available as standard, either locally via the rotary dimmer knob or remotely via DMX.



RJU0200	1166-2 CW
RJU0202	1166-2 NDW

Oz

The new dynamic long-throw model features an exclusive 600W cool white LED source and is the first professional LED followspot able to deliver a high output comparable with that of 1200W discharge followspots. With its compact dimension, silent operation, smooth electronic dimming and the benefits of no lamp change and powerful output, Oz is the perfect front of house spot for larger venues and full size theatres.



RJU0203	1169
RJU0204	1169TC

Alice

The new dynamic short-throw model features an exclusive 600W cool white LED source and is the first professional LED followspot able to deliver a high output comparable with that of 1200W discharge followspots.



RJU0209	1469
RJU0210	1469TC

Merlin

Ranging from 3° to 12°, Merlin is a versatile throw followspot offering the widest choice of ranges in one single unit. All the handling is amazingly good and easy: the levers for adjusting the beam size, the dimmer and even the different colour filters are within arm's reach.



Sully 305L

Sully 305LF luminaire combines a high-quality 115W white LED source with a single 150 mm / 6" Fresnel lens, which can be easily changed for a Pebble Convex lens. It is especially valuable in multi-purpose venues and rental companies where the interchangeable lens can be put to full use.



RJU0212	305LF WW
RJU0213	305LF CW
RJU0214	305LPB WW
RJU0215	305LPB CW

Lutin 306L

Lutin is a multi-purpose 1K fixture with a host of unique design features – including a choice of 3 quick-change lenses – making it the most versatile and economical unit of quality on the market. It can be used as a Fresnel for coverage, a Pebble for soft light and a PC for directional light.



RJU0216	306LF
RJU0217	306LPB
RJU0218	306LPC

310H

A large 200 mm lens gives unparalleled light output and quality of beam. The 310H is at home in every venue, large and small, and offers broad coverage with a smooth, even beam. Designed for easy maintenance, this unit has a well-earned reputation for reliability.



RJU0219	310HF
RJU0220	310HPB
RJU0221	310HPC

Sully 315L 4C

Providing a multi-faceted solution in a compact package, Sully 315L 4C combines a high-quality 200W 4-colour LED source (RGB Lime) with a single 200 mm Fresnel lens (315LF) or Pebble Convex lens (315LPB).



RJU0222	315LF 4C
RJU0223	315LPB 4C

Single Lens Luminaires



Cin'k 325LF

Cin'k's 250 mm lens gives an output which exceeds that of comparable 300 mm fixtures, and its theatre-inspired front cassette has no distracting light spill. An ideal tungsten source for theatres and opera houses, large venues and rental houses.



RJU0224	325LF
---------	-------

Cin'k 326L

Like its tungsten counterpart, its 250mm lens ensures a powerful output while the theatre inspired front cassette gives no light spill so providing an alternative to the current film lighting method of attaching filters with clips. Smooth dimming can be achieved with no change in colour temperature by the addition of a Jalousie 2 digital dimmer.



RJU0225	326LFV
RJU0226	326LFV
RJU0227	326LFVE

329H

329H is a favourite in theatres, opera houses and concert halls the world over. A G22 lamp socket holds the lamp securely in place giving reliability, longer lamp life and 2000 W or 2500 W lamp options. Ideal for medium to large venues and rental companies.



RJU0228	329HF
RJU0229	329HPB
RJU0230	329HPC

Cin'k 350L

Cin'k's 250 mm lens gives an output which exceeds that of comparable 300 mm fixtures, and its theatre-inspired front cassette has no distracting light spill. An ideal tungsten source for theatres and opera houses, large venues and rental houses.



RJU0231	350LF
RJU0232	350LFV

ZEP2

The Zep2 Fresnel represents an economical solution as it extends colour filter life due to its low heat output, and requires fewer maintenance calls thanks to its extra-long-life LED. Particularly attractive is its electronic



flicker-free dimmable PSU. The versatility offered by the choice of different colour temperatures makes the Zep2 perfect for studios, theatres, and events, as well as architectural applications.



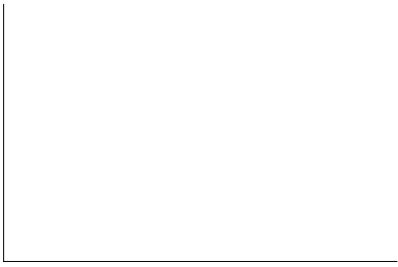



650SX 4C

651SX 4C

Sully 4C is a series of variable zoom profile featuring a 4-colour LED source and integrating an innovative software platform named RJ Color. With advanced setting and control modes, these profile spots deliver perfect whites and high quality saturated and pastel colours.



RJU0247	651SX 4C
---------	----------

653SX 4C

Sully 4C is a series of variable zoom profile featuring a 4-colour LED source and integrating an innovative software platform named RJ Color. With advanced setting and control modes, these profile spots deliver perfect whites and high quality saturated and pastel colours.



RJU0250	653SX 4C
---------	----------

654SX 4C

Sully 4C is a series of variable zoom profile featuring a 4-colour LED source and integrating an innovative software platform named RJ Color. With advanced setting and control modes, these profile spots deliver perfect whites and high quality saturated and pastel colours.



RJU0253	654SX 4C
---------	----------

650SX Series

Sully 651SX

The Sully 650SX Series is a variable zoom profile range featuring a high-quality 115 W warm white LED source (CRI = 98) that delivers a first-class white light and an output that far exceeds 1000 W tungsten luminaires and nearly matches that of 1200 W tungsten models.



RJU0245	651SX WW
RJU0246	651SX CW

Sully 653SX

The Sully 650SX Series is a variable zoom profile range featuring a high-quality 115 W warm white LED source (CRI = 98) that delivers a first-class white light and an output that far exceeds 1000 W tungsten luminaires and nearly matches that of 1200 W tungsten models.



RJU0248	653SX WW
RJU0249	653SX CW

Profile Spots

Tibo HE 553

Tibo HE 553 is a product evolution of the original 75 W LED Tibo 533 model. Tibo HE (High Efficiency) is a new mighty compact profile spot featuring a 115 W white LED engine. It offers twice as much light output and quality. Tibo HE delivers a very high CRI and guarantees a light output that far exceeds 1000 W tungsten luminaires and nearly matches that of 1200 W tungsten models. The power supply is now integrated into the unit to make it really compact and easier to incorporate into a design vi...



RJU0237	553WW
RJU0238	553CW

611SX

The most versatile of the Juliat profiles, the short throw 611 SX is equally happy on-stage, overhead, on side booms or prosceniums. Its advanced functions and optical quality make this fixture indispensable in opera houses, theatres and studios. Interchangeable lamp bases can be swapped with the Quincy range to give a choice of tungsten or discharge options.



RJU0239	611SX
RJU0240	611SX

613SX

The most versatile of the Juliat profiles, the short throw 613 SX is equally happy on-stage, overhead, on side booms or prosceniums. Its advanced functions and optical quality make this fixture indispensable in opera houses, theatres and studios. Interchangeable lamp bases can be swapped with the Quincy range to give a choice of tungsten or discharge options.



RJU0241	613SX
RJU0242	613SX

614SX

The most versatile of the Juliat profiles, the medium throw 614 SX is equally happy on-stage, overhead, on side booms, prosceniums or front of house. Its advanced functions and optical quality make this fixture indispensable in opera houses, theatres and studios. Interchangeable lamp bases can be swapped with the Quincy range to give a choice of tungsten or discharge options.



RJU0243	614SX
RJU0244	614SX



Sully 654SX

The Sully 650SX Series is a variable zoom profile range featuring a high-quality 115 W warm white LED source (CRI = 98) that delivers a first-class white light and an output that far exceeds 1000 W tungsten luminaires and nearly matches that of 1200 W tungsten models.



RJU0251	654SX WW
RJU0252	654SX CW

710SX2

Combining power with a smooth flat beam, the 710 SX2 is the perfect profile for all long throw applications in medium to large theatres and opera houses. Its secure G22 lamp socket ensures reliability, longer lamp life, and 2000 W or 2500 W lamp options.



RJU0266	710SX2
RJU0267	710SX2 Silent

ZEP2 660SX2 Series

ZEP2 661SX2 - 11/26°

Equipped with an enhanced white LED source providing a higher light quality and output, the ZEP 660 SX2 LED profile spot can be used as a direct complement or replacement for traditional 1k or 2k units but uses only 300W of long life LED power resulting in huge cost saving. Designed with Robert Juliat's trademark qualities of ergonomic perfection, optical and mechanical excellence, ZEP2 features a smooth flat beam, an excellent colour rendering index and suit every application from the smallest theatre to the largest spectacular.



711SX2

Combining power with a smooth flat beam, this extremely narrow lens is superb for very long throw distances with no oversized lens tube, and is perfect for medium to large theatres and opera houses. Its secure G22 lamp socket ensures reliability, longer lamp life, and 2000 W or 2500 W lamp options.



RJU0268	711SX2
RJU0269	711SX2 Silent

ZEP2 663SX2

Equipped with an enhanced white LED source providing a higher light quality and output, the ZEP 660 SX2 LED profile spot can be used as a direct complement or replacement for traditional 1k or 2k units but uses only 300W of long life LED power resulting in huge cost saving. Designed with Robert Juliat's trademark qualities of ergonomic perfection, optical and mechanical excellence, ZEP2 features a smooth flat beam, an excellent colour rendering index and suit every application from the smallest theatre to the largest spectacular.



713SX2

Combining power with a smooth flat beam, the 713 SX2 is the perfect profile for all short throw applications in medium to large theatres and opera houses. Its secure G22 lamp socket ensures reliability, longer lamp life, and 2000 W or 2500 W lamp options.



RJU0270	713SX2
RJU0271	713SX2 Silent

ZEP2 664SX2

Equipped with an enhanced white LED source providing a higher light quality and output, the ZEP 660 SX2 LED profile spot can be used as a direct complement or replacement for traditional 1k or 2k units but uses only 300W of long life LED power resulting in huge cost saving. Designed with Robert Juliat's trademark qualities of ergonomic perfection, optical and mechanical excellence, ZEP2 features a smooth flat beam, an excellent colour rendering index and suit every application from the smallest theatre to the largest spectacular.



714SX2

Combining power with a smooth flat beam, this medium throw fixture is a favourite for TV studios, talk shows and news reports, and perfect for medium to large theatres and opera houses. Its secure G22 lamp socket ensures reliability, longer lamp life, and 2000 W or 2500 W lamp options.



RJU0272	714SX2
RJU0273	714SX2 Silent

Ambiance Cyclight

Horus 850

Its light distribution and beam angle have contributed to its success. In addition, Horus is characterised by an ingenious gel holder system that enables rapid colour changing, without disturbing the fixture's settings and, as an advantage over similar products, it has been specially designed to perform without light spill. The unique RJ handle provides optimum grip during focusing and is designed for easy access to the power cable connector. Cable changing can be done in seconds.



RJU0274	850
---------	-----

700SX2 Series



Dalis 860	
<p>Dalis is an asymmetrical 300W LED cyclorama / wall wash luminaire designed to deliver powerful, smooth coverage and a huge variety of pastel and saturated colours. Dalis cyclight offers silent operation which is perfect for sound sensitive applications like opera houses and studios, and all theatrical, TV and entertainment applications.</p>	
RJU0342	860



Dalis 861	
<p>Sharing the same qualities of control, colour mixing, coverage and silent operation as Dalis Cyclight, Dalis 861 is the perfect wash complement to the Dalis range. Dalis incorporates eight coloured LED emitters (red, green, blue, royal blue, amber, cyan, warm white 2200K and cool white 6500K). The choice of these six colours in association with the two whites gives access to an extremely wide colour gamut.</p>	
RJU0343	861



Dalis Access 863	
<p>Dalis 863 Access is a 150W LED batten designed to give small-sized venues or those with smaller budgets the first access to Dalis technology. Sharing all the technology as the original Dalis 860 Cyclorama fixture, Dalis Access 863 features a four-colour mixing system and 24 of the patented Dalis asymmetrical micro-reflectors, but otherwise all the functionality and quality of the original. The batten delivers powerful, smooth coverage and a fair variety of pastel and saturated colours. It incorporates four coloured LED emitters (red, green, royal blue and warm white 2200K). Equipped with an advanced fanless cooling system, Dalis Access is equally perfect for cyclorama or footlight applications.</p>	
RJU0346	863



Footlights

Dalis 862	
<p>Offering a true tunable white from 2200K to 6500K, Dalis 862 footlight incorporates 48 patented asymmetric reflectors arranged in a double row. Each row can be controlled independently offering long or short throw capacities and creating upstage or downstage lighting.</p>	
RJU0344	862
RJU0345	862S



Dalis 864	
<p>Dalis 864 Footlight is a new 150W colour variation of the original Dalis 862 tuneable white footlight, designed for the creation of colourful upstage or downstage lighting. Featuring a 4-colour mixing system, it incorporates 48 patented asymmetric reflectors arranged in a double row, independently controlled. The Footlight batten is inconspicuous from the audience viewpoint to ensure it does not impinge on the stage layout. All controls and connections are located under the unit to maintain clean sight lines. Each unit also integrates four discreet red and blue 'mark' LEDs. They can be used as position markers or cue lights for the performers on stage, and also as safety indicators to mark the edge of the stage.</p>	
RJU0347	864
RJU0348	864S



Washlight